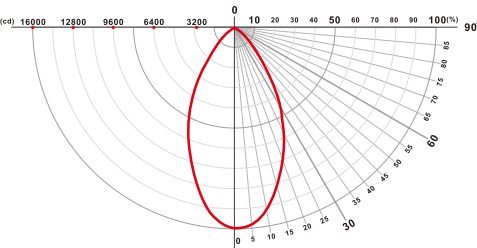
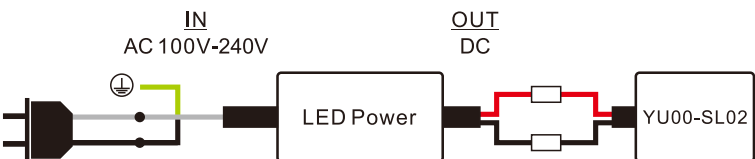

LED CARGO LIGHT

YU00-SL02

• To replace NHT-250/400
MT250/400BH
J750/1000

- IP66, Salt spray test and Vibration test compliance.
- Long lifespan up to 20,000 hours.
- Design according to Rules for the Construction and Classification of Steel Ships.
- Meet standard of JIS F 8442 and CNS10258.
- Noticeable reduce the fuel cost.
- Can be used in bad environment safely and stably.

Product	Part No.	Specification															
<p>Nichia Led</p>   <table border="1" data-bbox="231 1422 582 1624"> <tr> <td>Beam width: 1.2m</td> <td>16000 lux in center</td> <td>1m</td> </tr> <tr> <td>Beam width: 3.5m</td> <td>1778 lux in center</td> <td>3m</td> </tr> <tr> <td>Beam width: 6.9m</td> <td>444 lux in center</td> <td>6m</td> </tr> <tr> <td>Beam width: 10.3m</td> <td>198 lux in center</td> <td>9m</td> </tr> </table> <p>Beam Angle $\theta = 60^\circ$</p>	Beam width: 1.2m	16000 lux in center	1m	Beam width: 3.5m	1778 lux in center	3m	Beam width: 6.9m	444 lux in center	6m	Beam width: 10.3m	198 lux in center	9m	YU00-SL02	Power Consumption	135W	Luminous Flux	19500Lm
	Beam width: 1.2m	16000 lux in center	1m														
	Beam width: 3.5m	1778 lux in center	3m														
	Beam width: 6.9m	444 lux in center	6m														
	Beam width: 10.3m	198 lux in center	9m														
	Dimension	331x316x242mm	CRI	Ra 75													
Weight	7.5kg \pm 10%	CCT	5000K														
Input Voltage	AC 100V-240V	Beam Angle θ	60°														
Operating Temperature	-25°C~+50°C	Lux@1m	16000														
IP Code	IP 66																
International Standards	<ul style="list-style-type: none"> ■ CNS 14335 / 14165 IP66 ■ CNS 15233 Vibration test ■ CNS 8886 Salt spray test 																
<p>Wiring Diagram</p> 																	

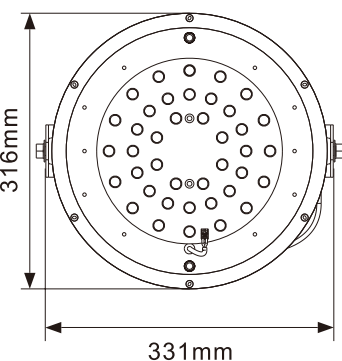
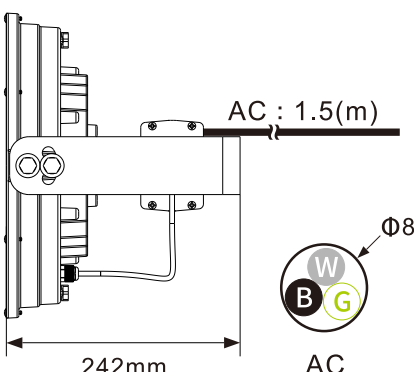
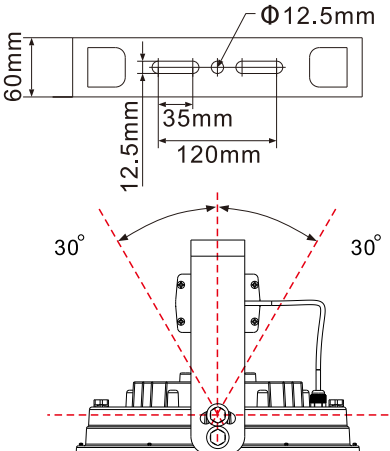
		
---	---	---